

PARTS

To raise the keyboard and monitor, pull the actuator handle (located under the right side of the work surface) upwards to release the lock. If additional force is required, apply a slight upward force to the opposite corner of the work surface or keyboard tray.

To lower the keyboard and monitor, pull the actuator handle (located under the right side of the work surface) upwards to release the lock. Provide the appropriate downward force on the work surface using the palms of your hands.

If you have difficulty lowering (i.e. it feels like the unit is stuck) provide additional downward force by gripping the actuator and apply additional downward force to the horizontal portion behind the column.

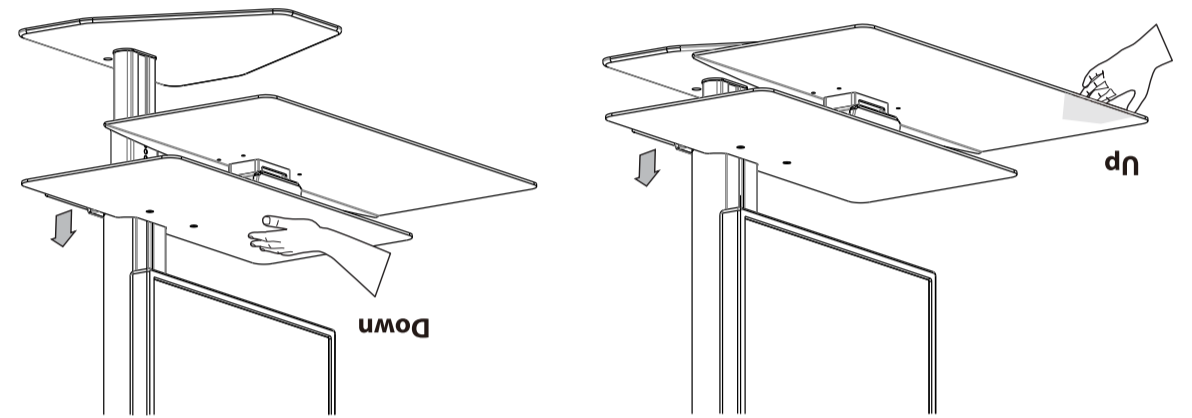

RAISE AND LOWER THE WORKSTATION

ASSEMBLY INSTRUCTIONS

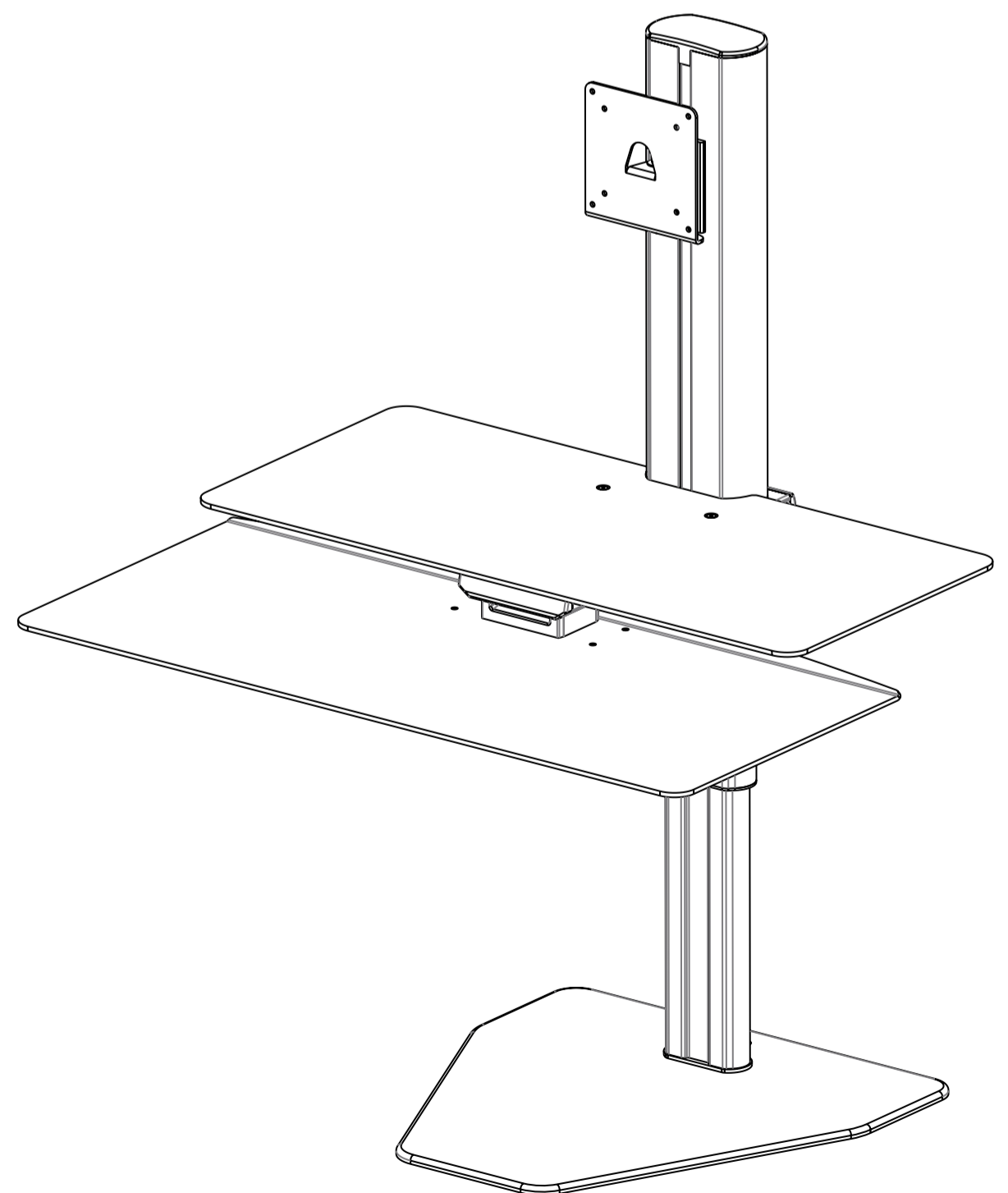

TYCHO™ Height Adjustable Workstation—Single Monitor

STEP 1

Remove one track from the underside of the work surface and set aside.

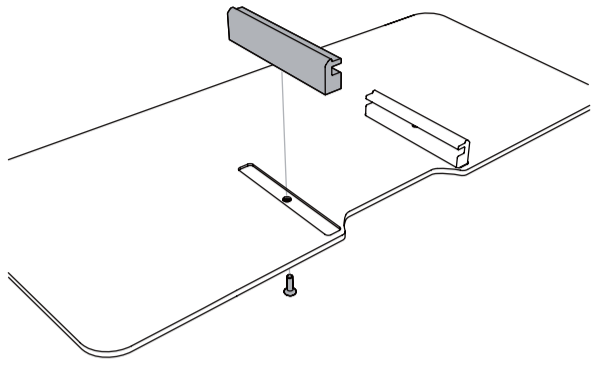

Insert the attached work surface track into the plastic guide on the column arm.

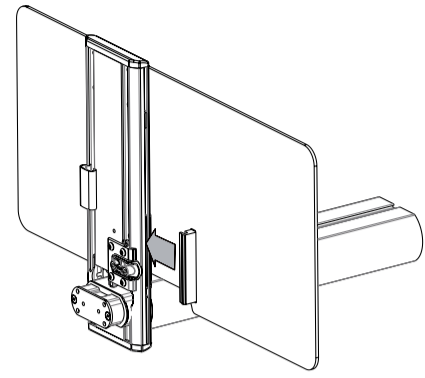

Insert the unattached work surface track into the opposite plastic guide on the column arm and attach using the screw you removed in step one.

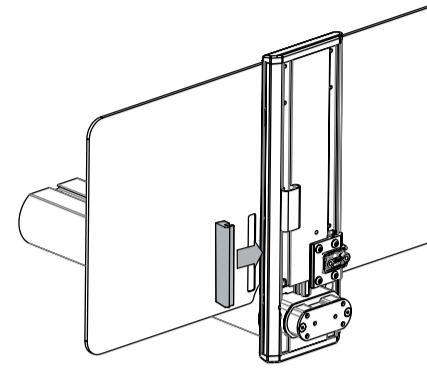

STEP 2

Rest the unit upside down over the edge of a desktop or work surface on top of cardboard divider (marked with "B" in packaging).

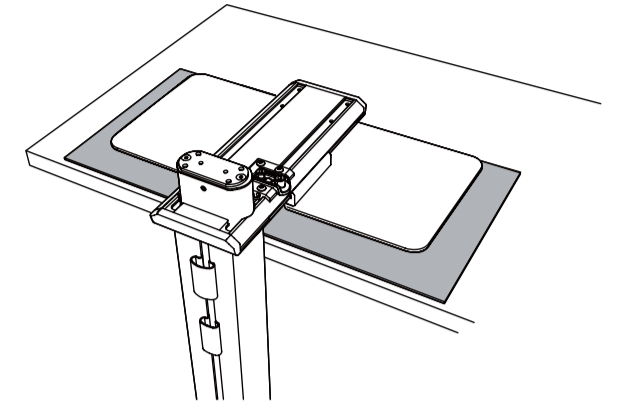

STEP 3

Attach the actuator handle as shown using the M5x12mm screws.

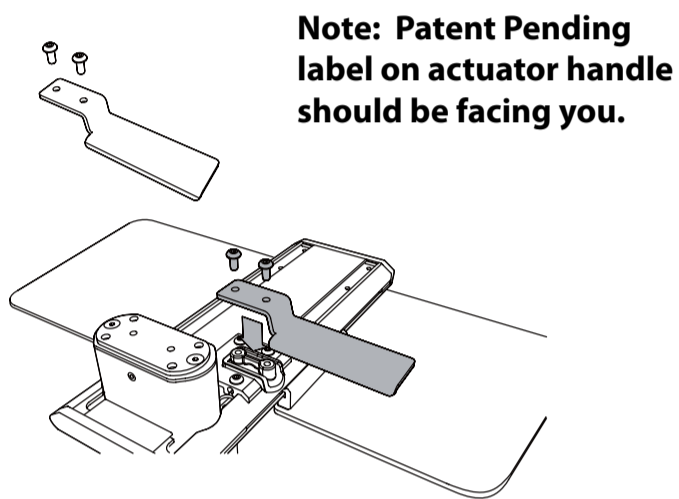

STEP 4

Set keyboard tray spacer and alignment to the holes on the column arm.

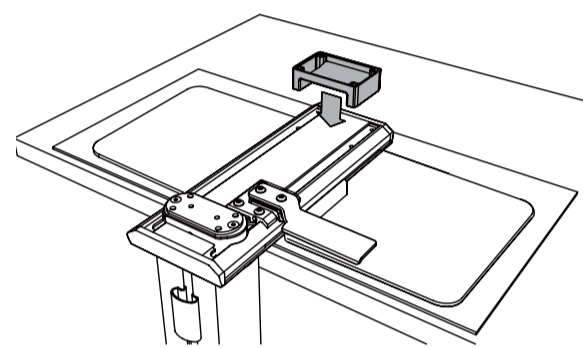

STEP 5

The Tycho allows you to align the keyboard tray to the left or right for better ergonomic positioning. With the bottom of the keyboard tray facing you use the darkened holes to attach the keyboard tray for your desired alignment.

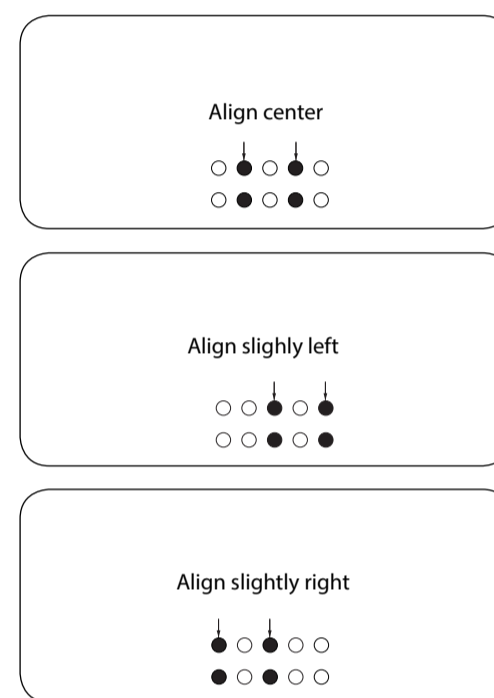

Place the cardboard spacer (labeled "A" in packaging) in front of the unit as shown to support the keyboard tray) and attach the keyboard tray to the column arm using the M5x38mm screws through the spacer.

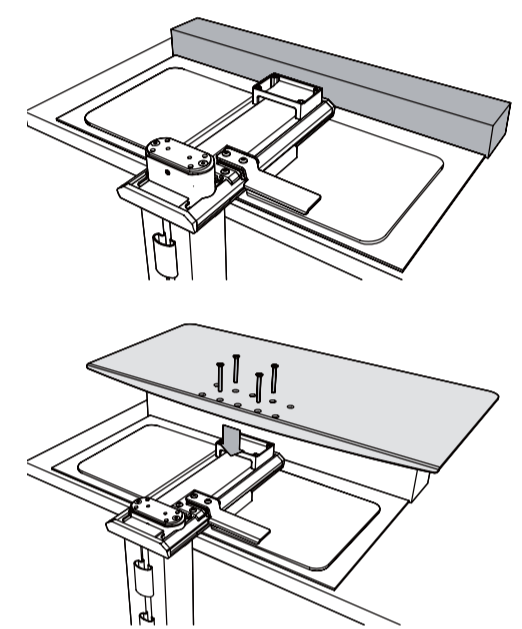

STEP 6

Foam pad instructions:

- Place the template provided on the underside of the keyboard tray as shown.
- Remove adhesive liners and affix foam pads into openings on the template.
- Remove the template.

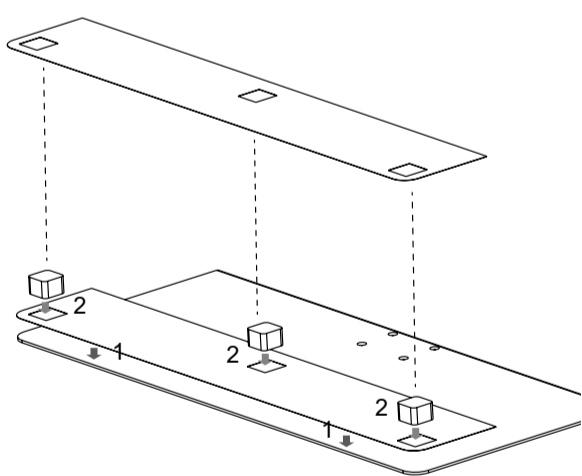

STEP 7

Place some of the bubble wrap on top of the keyboard tray and then attach the baseplate to the vertical column using the M5x25mm screws. Note: the countersunk holes and felt pads of the steel baseplate should be facing you.

When the baseplate is firmly attached, flip the unit onto the desktop or work surface where you plan to use it.

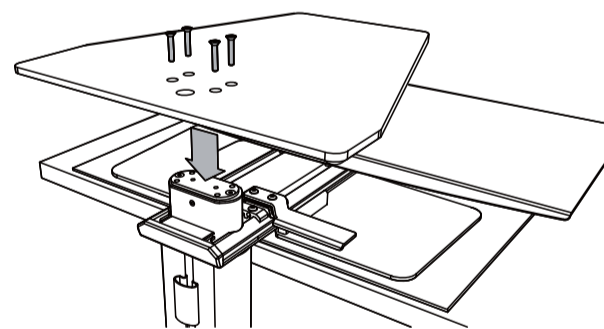

STEP 8

For standard monitors attach the VESA mount to the monitor with the M4x12mm screws and the countersunk washers. For monitors with a recessed area for VESA mounting, place the spacers between the monitor and the VESA mount. Mount the monitor with the M4x22mm screws and the countersunk washers.

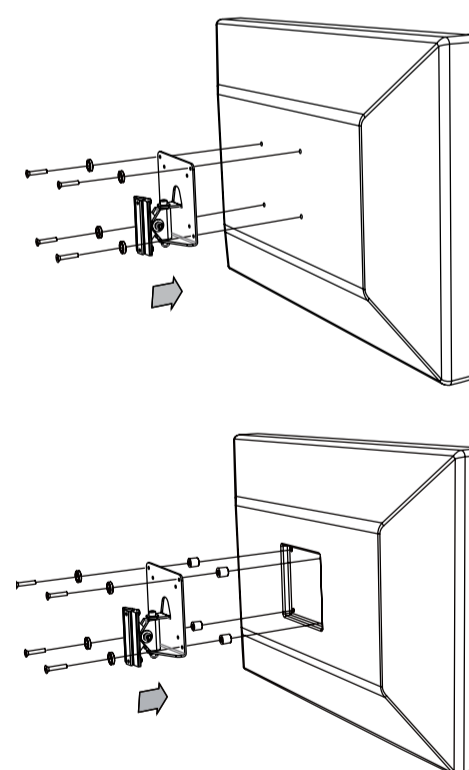

STEP 9

Slide mounted monitor into the channel adjusting the appropriate height. Tighten the top and bottom screws to lock the monitor in place.

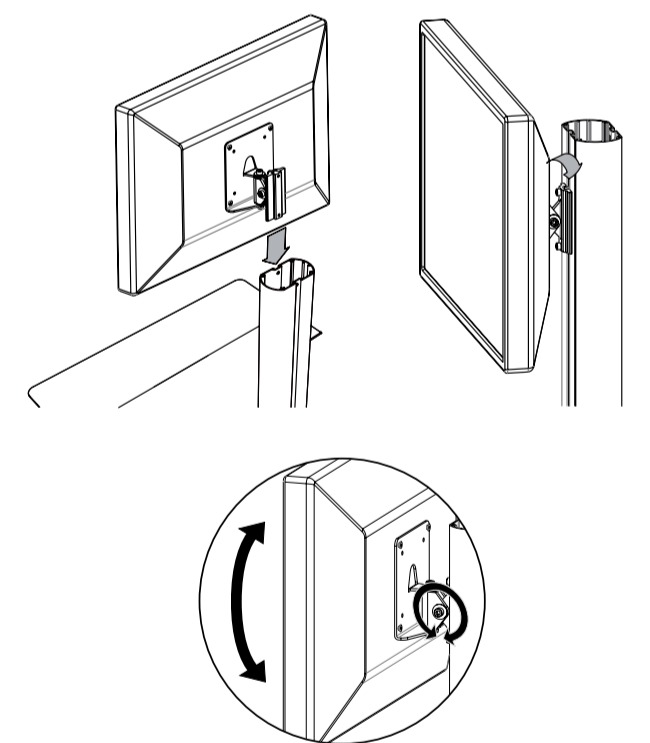

Note: To adjust the forward/backward tension of the VESA mount, loosen or tighten the tension bolt with the included hex key and wrench. Do not do this until you have mounted the monitor(s) on the base unit.

STEP 10

Affix the plastic cap to the top of column as shown.

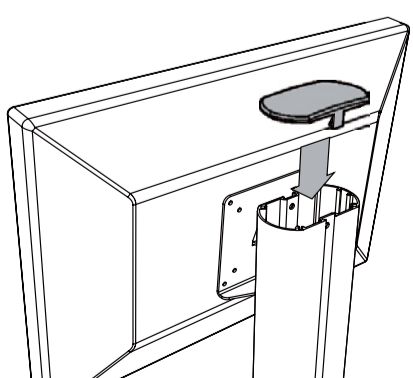

STEP 11

Align cables from monitor towards the center of the column, insert cables into the cable management clips and clip the cable management clips into the center channel of the column.

